

TagMaster AB

Communicator Holders

General

The following products are used for attaching communicators in the CONFIDENT family to fixed objects such as walls, ceilings, columns and poles.

All products are made of corrosion stable material such as plastic, rubber and stainless steel. A mechanically strong outdoor paint has been used on painted parts.

A set of screws, washers and other mounting accessories is included in the product. Each product is also supplied with a small manual with mounting instructions.

S1952/00 ComFix

ComFix is used when S1500 and S1501 are to be mounted on flat surfaces, such as walls, indoor or under roof outdoors. The unit comprises a polymer balljoint, allowing 360° rotation and ±40° tilting. The joint is fixed to a corrosion stable stainless steel plate, that is designed for attachment to S1500 and S1501 communicators.

The size of the steel plate is adapted for precise tightening against the rubber gasket around the edge of the communicators, to provide extra sealing against climatic influences.

S1956/00 PoleFix

PoleFix is intended for outdoor pole mounting of S1500 and S1501 communicators. It fits on poles with a diameter of 40 to 60 mm. The communicator is mounted under a rainshield which also is tightening against the rubber gasket on the back of the communicator to provide extra sealing.

The S1956/00 Polefix is able to tilt 15° up and 35° down. It can also be turned 360° around the pole, all for optimal reading range performance.

S1957/00 PoleFix LR

Use PoleFix LR when mounting S1503 WiseMan Long Range communicators on poles with a diameter of 40 to 60 mm.

The design allows the unit to be rotated 360° around the pole and tilted 50° down and 25° up.

S1958/00 WallFix

WallFix is intended for S1500/S1501 communicators which are to be mounted on the wall or in the ceiling. The product is specially designed for outdoor use and the communicator is covered with a rainshield.

A balljoint allows the unit to be tilted ±40°.

S1959/00 WallFix LR

Chose this product when S1503 WiseMan Long Range communicators are to be mounted on wall or in ceiling in- or outdoors.

The product comprises of a mounting plate on which the communicator is fastened and a balljoint for 360° rotation and ±40° tilting.

Product	Communicator type		For mounting on		Mounting environment	
	S1500/1501	S1503	Wall	Pole	Indoor	Outdoor
• S1952 ComFix	√		√		√	
• S1956 PoleFix	√			√	√	√
• S1957 PoleFix LR		√		√	√	√
• S1958 WallFix	√		√			√
• S1959 WallFix LR		√	√		√	√

Mechanical data - S1952/00 ComFix

Dimensional drawing

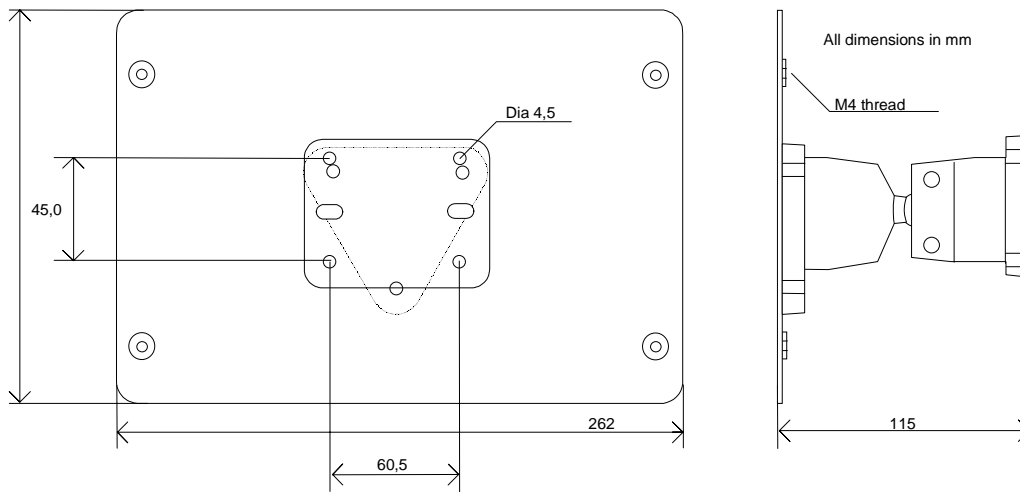

Weight

S1952/00 0.7 kg

Colour

Metal plate: Shiny
Joint: White

Materials

Metal plate Acid stable stainless steel
Joint Polyamide

Marking

The product is not marked

Mechanical data - S1956/00 PoleFix

Dimensional drawing

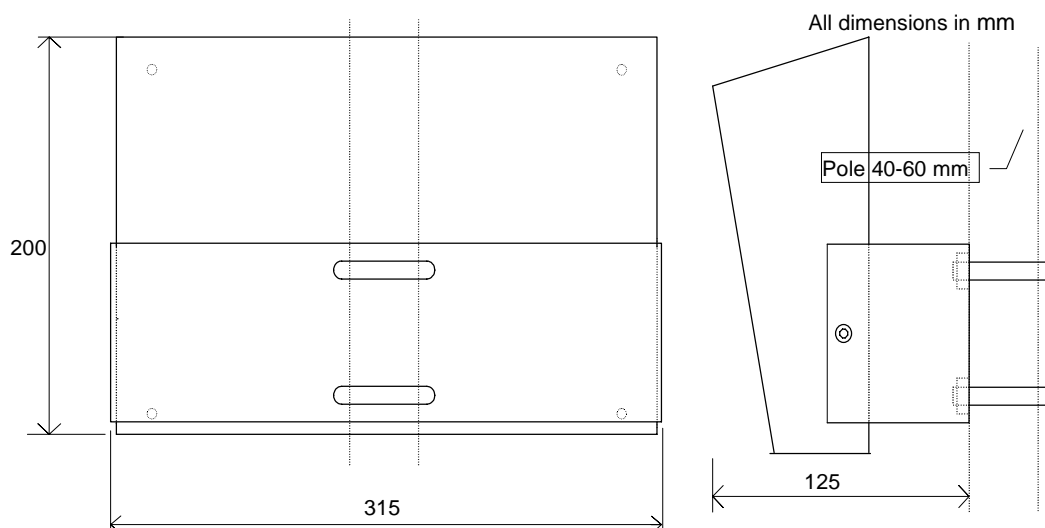

Weight

S1956/00 2.8 kg

Colour

Metal plate: Cool grey
Joint: White

Materials

Metal plate Acid stable stainless steel
Joint Polyamide

Marking

The product is not marked.

Mechanical data - S1957/00 PoleFix LR

Dimensional drawing

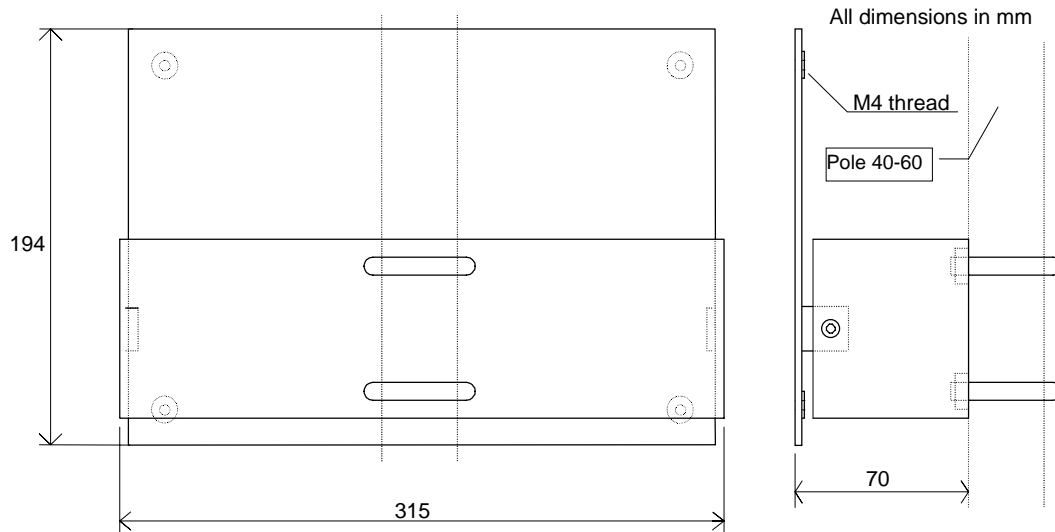

Weight

S1957/00 2.3 kg

Colour

Metal plate: Cool grey

Materials

Acid stable stainless steel

Marking

The product is not marked.

Mechanical data - S1958/00 WallFix

Dimensional drawing

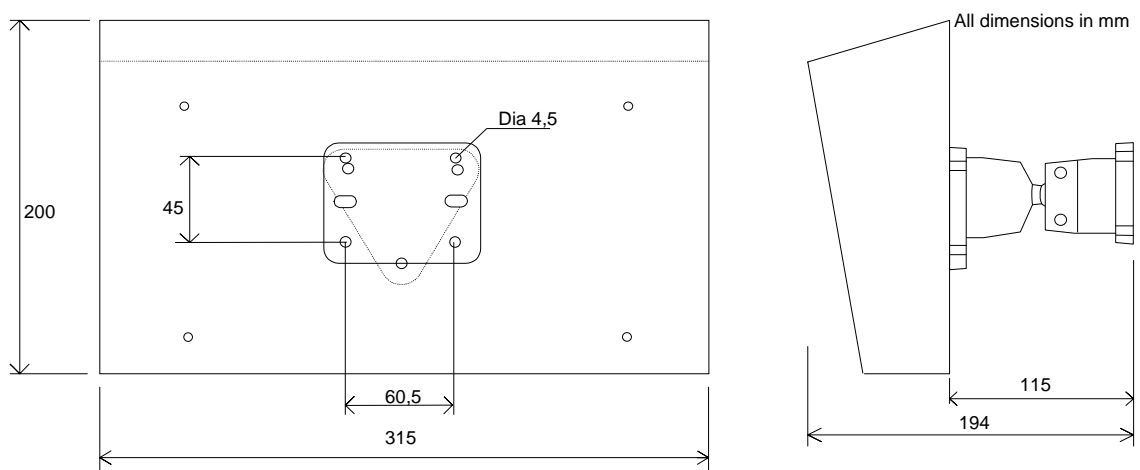

Weight

S1958/00 2.0 kg

Colour

Metal plate: Cool grey

Joint: White

Materials

Metal plate Acid stable stainless steel

Joint Polyamide

Marking

The product is not marked.

Mechanical data - S1959/00 WallFix LR

Dimensional drawing

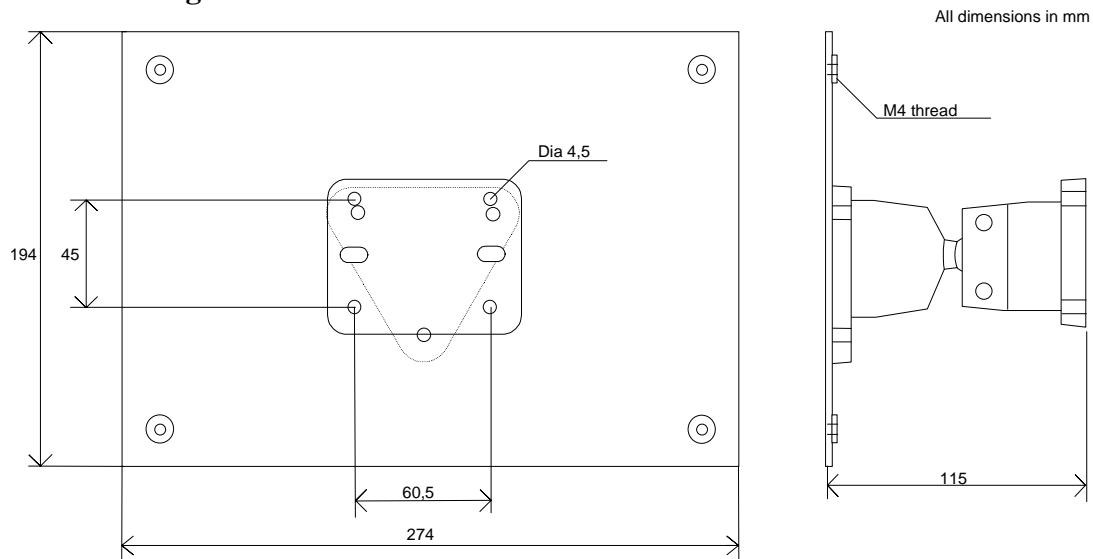

Weight

S1959/00 1.4 kg

Colour

Metal plate: Cool grey

Joint: White

Materials

Metal plate Acid stable stainless steel

Joint Polyamide

Marking

The product is not marked.

This document

Specifications and design are subject to change without prior notice.

Representative:

ds1952 bb 9909

TagMaster AB

Electrum 410 Tel +46 - (0)8 632 1950

S-164 40 KISTA Fax +46 - (0)8 750 5362

Sweden

e-mail: confident@tagmaster.se

web site: <http://www.tagmaster.com>