

TagMaster AB

S1503 Long Range Communicator

User programmable Read/Write station

S1503 Long Range communicator is a 2.45 GHz circular polarised read/write station for Confident RFID tags. Reading distance is up to 6 metres. The communicator has 100 RF channels eliminating any interference of other nearby communicators. Transmitted power and reception sensitivity is also adjustable with SW commands for optimising any installation.

S1503 has a movement detection function for detecting people and vehicles, or even smaller objects, even if not using a tag. It can determine their moving speed in approaching or retreating directions.

S1503 is user programmable and has a large memory for application programs and built in database functions for fast, customised and efficient stand-alone operation. User software is downloaded and saved in EEPROM through a serial communication line. If user programming is not required, there is a ready-to-use standard application SW in the communicator.

A local database in EEPROM can be loaded with over 15,000 tag entries for extremely fast read-validate-activate response times.

The ConfiTalk protocol is used for serial communication in a polled RS485 network or point-to-point in RS232 connections. There are ConfiTalk communication drivers available for DOS, Windows 3.1 and Windows 95/NT with interface for C/C++, Delphi and Visual Basic.

S1503 has two serial ports, a DTMF port for keypads, LED interfaces, relay, parallel I/O (emulating magcard data as an option).

A control panel with a 7-segment LED display, two push buttons, a three colour LED, a buzzer and a reset button is available for local configuration and start up of test programs as installation aids. The unit can also be configured using a hand held computer or terminal connected locally.

S1503 is sealed from water spray and dust. Non corrosive materials are used in external parts. Connections are made through rubber bushings, or via cable glands. Jackable screw connectors connect the wires. Built in DC/DC converters tolerate noisy voltages, provide low power consumption (3W) and accept 24 as well as 12 V_{DC}

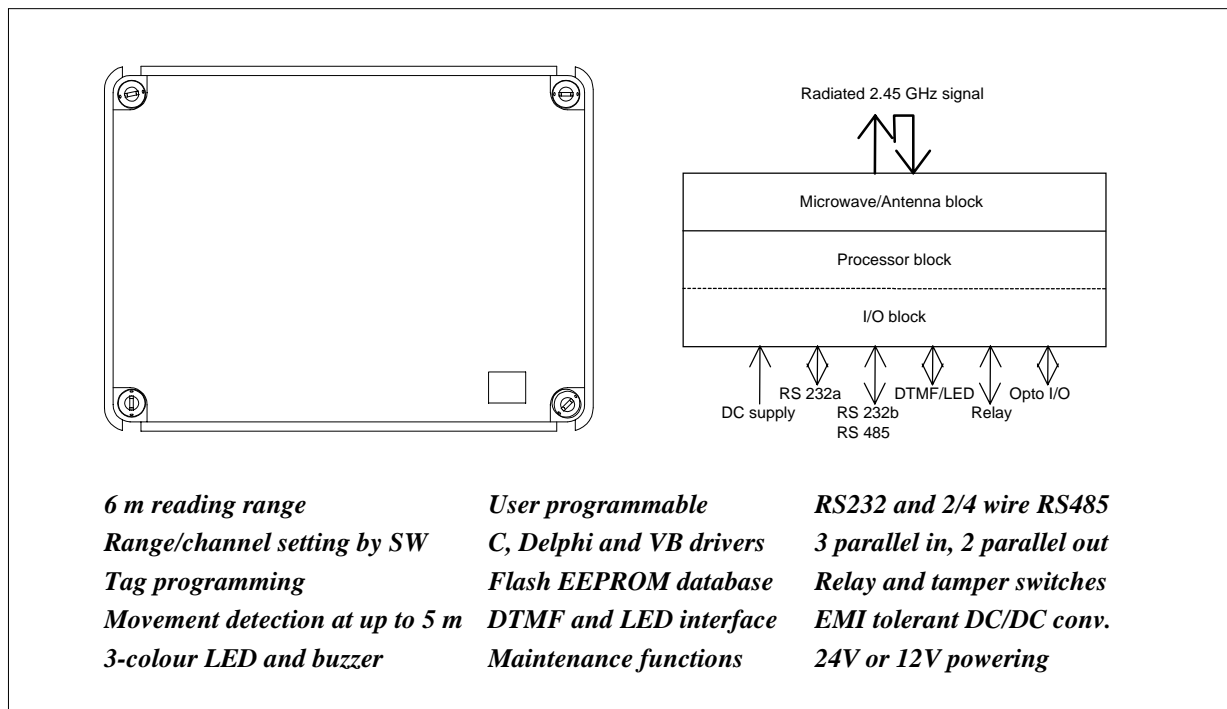

CONFIDENT

General

S1503 comprises a plastic cover and within a metal chassis for two PC boards, where the upper position carries a standard board and the lower is for an option board. A rubber gasket seals the unit.

The standard board includes a Processor and I/O block with analog and digital circuits, and is integrated with a Microwave and Antenna block.

The antenna system is circular polarised and radiates through the front cover, with a lobe that is directed perpendicularly to the front surface of S1503. The lobe shape can be described as an ellipsoid with a circular cross section, as shown in the figure below.

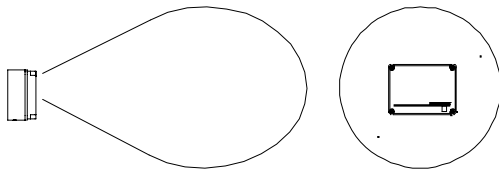

The reading and writing distances depend on the tag type and on the power and sensitivity SW settings. Typically, S1503 can read Confident tags at up to 6 m distance. See *Reading/Writing range* for reference.

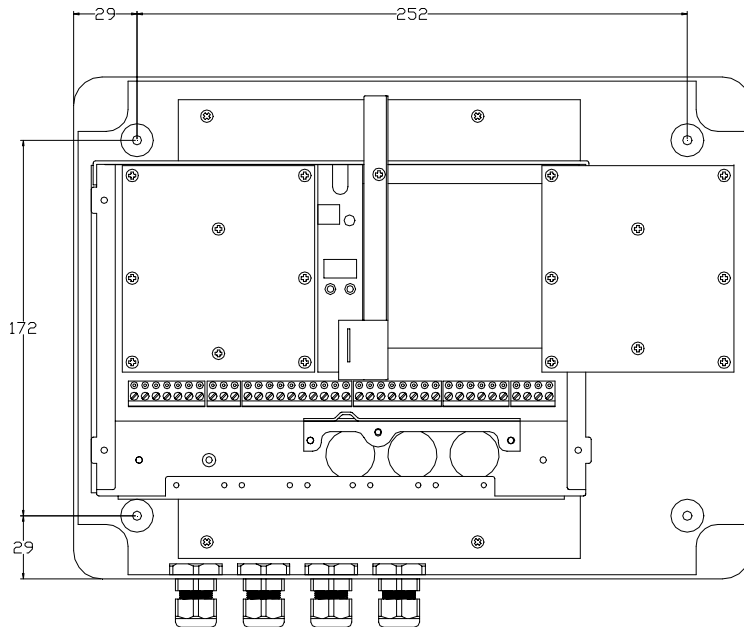

When dismantling the cover, it separates from the cable inlets to conveniently operate the unit also without cover. Screw connectors are jackable and in logical groups, i.e. it is not needed to disconnect each wire to replace the electronics.

J1	DTMF, LED, external tamper line
J2	RS232 for terminal
J3	RS232 and RS 485 for host
J4	Parallel out and relay
J5	Parallel in
J6	DC supply

Dual tamper switches monitor that the cover is closed. When removed, a software as well as hardware alarm is generated.

For service and setup purposes there is a control panel with a 7-segment LED display, 2 control buttons, a reset button, a LED and a buzzer. There are also jumpers for RS232/485 and 12/24V selection.

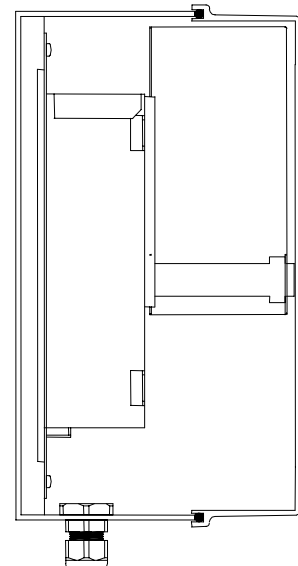

Reading/writing range

The maximum reading or writing range is defined as the maximum distance along the radiation axis where the tag can be communicated when the tag and communicator face each other and when there is free space in between.

The reading range depends on the tag reflectivity, the data speed (high/low), power output and sensitivity settings all resulting in R parameters for the tag and communicator. Multiply these factors and the resulting reading range is found.

Example: The R_{1503} for S1503 is 4.0 and the $R_{1251, \text{low speed}}$ for the S1251 tag is 1.5 resulting in a reading range of $4.0 * 1.5 = 6.0$ meters. This assumes the high power and high sensitivity is used.

If using low power and/or low sensitivity the reading range is reduced according to the following table.

Range	Sensitivity	Power	Range factor
4	HIGH	HIGH	100%
3	HIGH	LOW	50%
2	LOW	HIGH	25%
1	LOW	LOW	12%

The same applies for the writing range where you multiply the W factors for the tag and communicator to find the resulting range.

Example: The W_{1503} for S1503 is 1.0 and the W_{1251} for the S1251 tag is 0.5 resulting in a writing range of $1.0 * 0.5 = 0.5$ meters. This assumes the high power, high sensitivity and high speed.

Writing must be done at high power. The writing range is normally not affected by speed and sensitivity settings.

Lobe width

The lobe diagram shows, in a proportional scale, the approximate lobe shapes of the S1503 communicator.

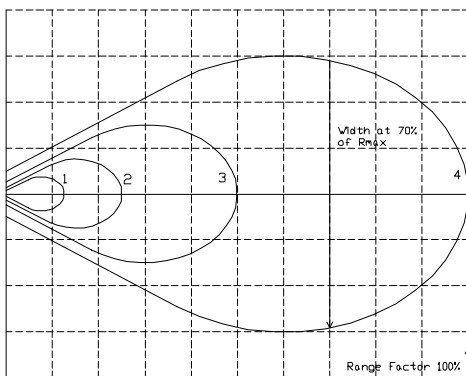

Curves 4, 3, 2 and 1 show areas for safe reading for the four different combinations of power and sensitivity. Once the reading range is determined for a combination of tag and communicator, the lobe width, or passage path, is easily found in the diagram.

Example: Your reading range has been calculated to 6.0 meters, meaning each square in the diagram is $6.0/10=0.6$ meters. The lobe width at 70% range is then $5.5 \text{ squares} * 0.6 = 3.3$ meters.

The diagram concerns a free space installation, and does not take into account possible influences from signal reflections or attenuating structures.

For reliability reasons, it is recommended that tags are passing at 70 % or less of maximum reading and writing range.

Reading/writing time

The time for reading and writing tags are specified in the tag data sheets. Please refer to the data sheet of the specific tag concerned.

Passage speed

The table shows the maximum allowed passage speed in km/h for combinations of tag reading time and lobe widths.

Reading time [ms]	Lobe width [m]				
	1.0	1.5	2.0	2.5	3.0
50	72	108	144	180	216
70	51	77	103	129	154
100	36	54	72	90	108
130	28	42	56	69	83
150	24	36	48	60	72
200	18	27	36	45	54

Tag orientation

Thanks to the circular polarisation, the reading and writing ranges are independent from the rotational orientation around the radiation axis. However, if the ID tag is very tilted in relation to the communicator, a range reduction may occur. Since this effect depends mainly on the specific installation, it is recommended that a test is made. S1503 can be set to a "read beep" mode to conveniently check out the reading range.

Movement detection

S1503 detects a moving person or car at up to 5 meters distance, even when moving slowly. The communicator senses if the object is approaching or moving away from the communicator, and at what radial speed. The detection threshold can be set to different sensitivity levels.

Processor block

The processor block includes a 16 bit microprocessor, 384 kByte Flash EEPROM, 100 byte EEPROM, 128 kByte SRAM and a bus interface for an external option board. Option boards are inserted in the lower position slot.

Flash EEPROM is used for program code and data-bases while the small EEPROM may be used for configuration data. This information is retained even after DC power interruption for any period of time. Programs and configuration can therefore be downloaded at production time and remains unchanged even after transportation.

The SRAM memory is used for program data, tag reading logs, communication mail messages, etc.

The processor block includes a real time clock (RTC) and a watchdog for automatic restart in case of software failure.

A rechargeable backup battery for SRAM and RTC is automatically charged as soon as the unit is under voltage, and retains its voltage during two weeks after loss of power provided that the battery jumper is in the on position.

Electrical data

Data regards the temperature range -20 to 60 °C.

<u>Parameter</u>	<u>Value</u>	<u>Unit</u>
DC Supply voltage	20 - 28	V
(selectable by jumper)	10 - 14	V
Consumption 12 V	500	mA
Consumption 24 V	150	mA
Radiation frequency	2435 - 2465	MHz ¹⁾
Polarisation	circular	
Tx modulation	ASK	
Channel spacing	300	kHz
Number of RF channels	100	
Radiation reduction	-12	dB
Sensitivity reduction	-24	dB
Reading data speed, high	16	kbit/s
Reading data speed, low	4	kbit/s
Writing data speed	4	kbit/s
Movement det., min speed	0,3	m/s
Movement det., max speed	9,2	m/s
Movement det. max range	5	m

1) The documented reading range is only valid within the frequency band 2446 - 2454 MHz. This corresponds to the channels 38 - 64.

Jumper settings

There are jumpers for selecting if the second serial port should be RS232 or RS485 and if the RAM backup battery shall be connected. See figure below.

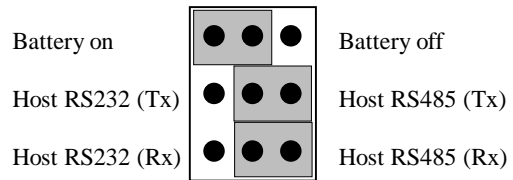

Under the rightmost antenna, additional jumpers are available for setting the unit to 12 or 24 volt operation. Markings on the PC board indicate how to set these jumpers. The factory setting is 24 V.

Control panel setup

Under the cover of the S1503 there is a control panel available for local configuration and operation without the need of a terminal or PC.

The left black button is used for parameter selection and the right black button is used for value selection.

Example to change the ConfiTalk address: Push the left button repeatedly until 'Ad' is displayed. Push the right button to display the current address. Repeat pushing the right button until the wanted address is displayed. Press the left button to save the configuration. When there are unsaved changes, the LED is red.

The configuration is stored in non-volatile memory, and is retained after a power failure.

To reset the communicator to default configuration and erase the database, keep the two black buttons pushed while pressing the red reset button. Release the buttons when the LED blinks yellow. Push the red button again.

To invoke the terminal interface Check SW in S1503, keep one of the two black buttons pushed while pressing the red button.

Software

The communicators are delivered with the pre-installed software Pyramid for standard applications. However, you can easily develop your own application software to be executed inside the communicator. This will give you the full power of controlling the communicator operation for flexible solutions and fast response times.

User application development

For user application development there are complete software development kits (SDK) including compilers, loaders, tools, drivers and libraries supporting the complete development phase for communicator applications as well as PC applications.

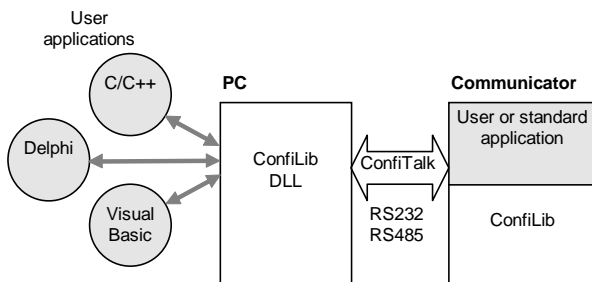

Communicator applications are developed in a PC environment with the cross compiler ConfiComp and can be executed in the PC for testing and debugging. The complete software is finally downloaded, using ConfiLoad, to the communicator for permanent storage in EEPROM. PC applications are developed with any PC software development tool. For application programmers a ConfiTalk Commander is available for training and low level communications management.

ConfiLib

ConfiLib is a function library with hundreds of functions for communicator management and ConfiTalk protocol handling. ConfiLib exist in versions both for communicators and PC environments including DOS, Windows 3.1 and Windows 95/NT.

The communicator version of ConfiLib is a function library package in C language. For PC environments, the ConfiLib API comes as dynamic link libraries (DLL) with C/C++ interface. There are also separate interface modules for Visual Basic and Delphi available. Typical functions include read/write/format tags, read/write/search database, HW/SW configuration, read/write I/O, ConfiTalk send/receive, timers, buffers, mail management, etc.

ConfiTalk

ConfiTalk is the standard serial communications protocol used by the communicators. The protocol transfers data to and from a communicator and handles flow control, retransmissions, checksums and data transparency. It can be used both for point-to-point and mul-

tidrop networks, using a polling procedure. The frames have the following structure:

STX	ADR	MESSAGE	CS	ETX
-----	-----	---------	----	-----

The STX field is the start-of-text character.

The ADR field is the address and sequence number.

The MESSAGE field is the data to be transmitted.

The CS is a checksum for transmission error detection.

The ETX is the end-of-text character.

ConfiTalk can be replaced by a user defined protocol.

Pyramid application

Pyramid application operates stand-alone reading tags, validating according to a downloaded database white list, activating relays for valid tags and producing logs for a PC to collect on- or off-line. Pyramid can also sense movements of people and vehicles using the movement detection.

Events

Following events may trig actions:

- A tag is read
- A tag is read and found in the database (validated)
- A movement is detected

Actions

For each event following actions may be specified:

- The event is logged
- The relay is pulled
- The buzzer is turned on
- The LED is set to different colours

Alarms

Following alarms can be generated:

- Tamper switch alarm
- Reset alarm

Database

The database in S1503 stores more than 15.000 tag identities.

Movement detection

When enabled, this feature can sense movements 5 meters away or at reduced ranges.

Timer

Relay activation time and tag timeout can be set.

Logging

All events and alarms are logged to be retrieved by a PC on- or off-line. Log size is 250-1000 events.

Terminal

For serial port configuration and local operating at installation time, an optional terminal can be connected to the terminal interface Check SW.

Pyramid may also be set to Off mode without any stand-alone operation. Instead, all ConfiLib commands are available on the serial port interface for a PC controller.

Hardware interface

The I/O block comprise the following interface.

DTMF

2-wire interface to receive a dual tone signal and to power a DTMF device.

Parameter	Min	Max	Unit
Line volt. @ 10 mA	4.1	4.5	V
Tone level	-26	0	dBm

RS 232 - host and terminal

Default: 9600 bps, 8 bits, no parity, 1 stop bit, ConfiTalk address 1

Parameter	Min	Max	Unit
Baud rate	1.2	19.2	kbits/s
Data bits	7	8	bits
Stop bits	1	2	bits
Parity	no - odd - even		

RS 485 - host

Full (4 wire) or half duplex (2 wire). Default: 9600 bps, 8 bits, no parity, 1 stop bit, ConfiTalk address 1

Parameter	Min	Max	Unit
Baud rate	1.2	38.4	kbits/s
Data bits	7	8	bits
Stop bits	1	2	bits
Parity	no - odd - even		

Optocoupler inputs

Parameter	Min	Max	Unit
High voltage	2,4	30	V
Low voltage	0.0	0.2	V

Open collector outputs

Parameter	Min	Max	Unit
Allowed voltage	1	30	V
Sink current Out 1	0	500	mA
Sink current Out 2	0	100	mA

Relay

Parameter	Min	Max	Unit
Switch current	2	A	
Switch voltage DC	220	V	
Switch voltage AC	125	V	
Switch power	50	W	

Power

If S1503 is powered with 24 VDC and the power cable length exceeds 3 m, a filter according to the figure below shall be added to ensure compliance with the requirements for conducted emission (ETS 300 683).

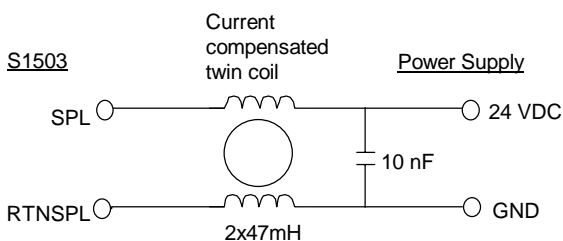

Connection diagram

The electrical interface is shown in the diagram below. J1, J2 etc. represent different logical (as well as physical) connectors, which can all be individually disconnected.

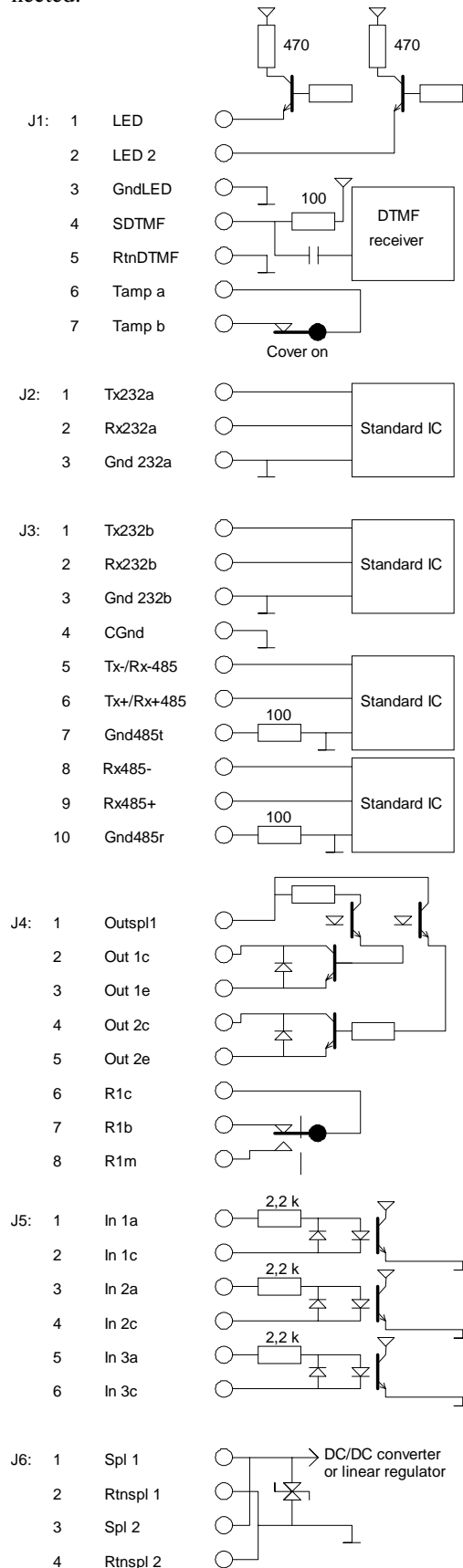

Installation aspects

Microwaves penetrate most non metallic materials, such as gypsum, wood, plastics, glass, dirt and snow. The unit should however if possible be installed and used so that free space is available between the ID tag and the communicator.

If large reflecting surfaces are present in the reading zone, the antenna diagram may be distorted. In such a case, it is recommended to shorten the distance to the ID tag to achieve a stronger signal. The system works safely at all distances down to zero.

If the communicator is installed with a low grazing angle to a reflecting surface such as a road or floor, the multipath effect can increase the reading distance. Since the multipath effect may reduce the lobe width, a test is recommended to check the communication in such installations, e.g. with the "Read Beep" test function available at the control panel.

In the control panel, push the left black button until "OP" is displayed. Press the right button until "rb" is displayed. Press the left button again. In the read beep operation mode, a short beep is sounded from the buzzer every time a tag is read, thus helping to verify the actual reading zone at installation time.

Restore the communicator to normal operation mode by pressing the right button until "On" is displayed and then press the left button.

If several communicators are to be operated close to each other, it is recommended to use different RF channels to avoid interference. There are 100 channels available.

If tags are passing at a close distance from the communicator it might be a recommendation to reduce the reading range to avoid unwanted readings of a remote tag. The range is reduced by setting of the power and sensitivity parameters.

If the communicator is to be used in wet conditions, the cable inlets should be oriented downwards. It is recommended to protect the communicator from direct water spray or rain.

Screened cables shall be used with the screens clamped according to the figure below.

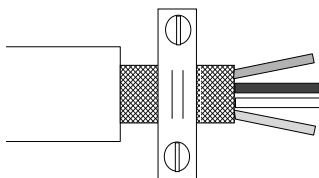

Note. The DTMF input may be disturbed if the DTMF cable is exposed to signals in the 1 - 3 MHz region and the prescribed test level (ETS 300 683) for conducted interference is exceeded.

Success

To enable a quick start to Confident products, the SACCESS Windows application is available for demonstration purposes.

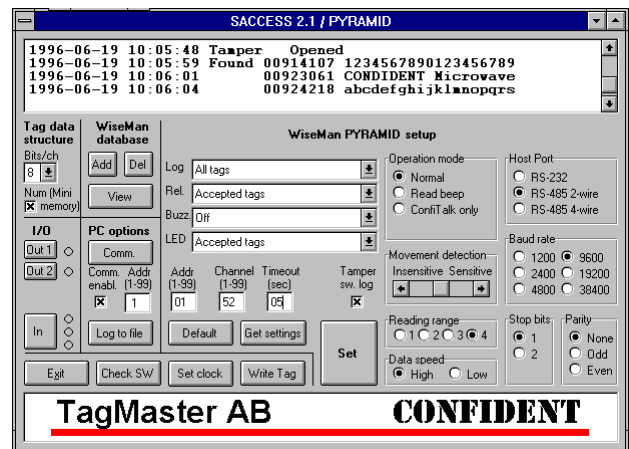

The main functionality is:

- Tag reading
- Tag writing
- Stand alone capability with tag validation and relay activation
- Database update
- Event and action configuration
- Logging events on screen and file
- Communicator serial port and address configuration

S1503 characteristics

The S1503 Long Range is a special version of the standard S1500. The following is the characteristic differences compared to S1500.

- The reading range is increased.
- The cover is larger and completely in plastic. There is no need for separate rain protections using this cover.
- It is based on the same hardware with additions and enhancements to increase the reading performance.
- The internal mechanics is different. However, all connectors etc. are still the same and compatible.

The hardware and software interface is identical to the S1500. Any application software developed for the S1500 should work properly unmodified in the S1503.

Mechanical data

Product information according to the figure below is marked on the cover of S1503.

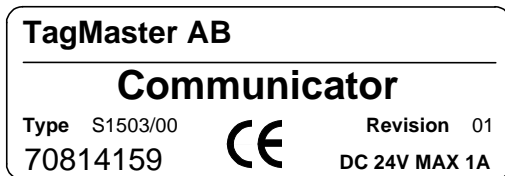

The revision code is for internal use only.

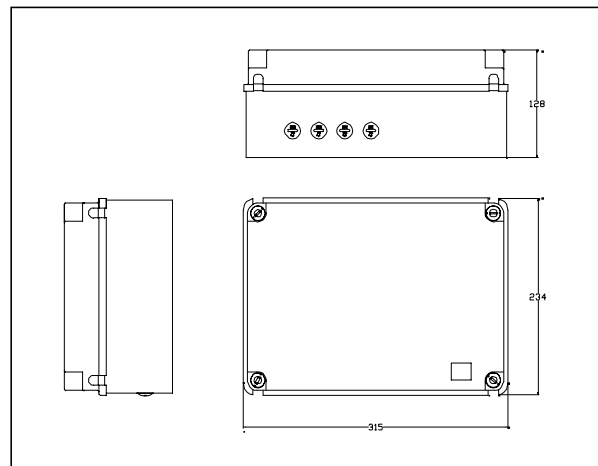

Weight	3.0 kg
Cover colour	Light grey
Cover material	Polycarbonate, polypropylen
Sealing method	Rubber gasket

Communication range data

Reading range parameter:	R	4.0	(6.0m with S1251 and S1450 in low dataspeed) (4.0m with S1251 and S1450 in high dataspeed)
Writing range parameter:	W	1.0	(5.0m with S1255 and S1455) (minimum 0.25m with S1251 and S1450)

The interpretation of the R and W parameters are described in the Reading/Writing range chapter in this data sheet.

Environmental data

Cold IEC68-2-1 Ad	- 20 °C	Shock IEC68-2-27 Ea	50 g 6 ms, 10x 3 dir	Immunity prETS 300 683	Acc. to CE leg.
Heat IEC68-2-2 Bd	+ 60 °C	Bump IEC68-2-29 Eb	15 g 6 ms, 1000x 3 dir	Emission I-ETS 300 440	Acc. to CE leg.
Sealing IEC 529	IP 56	Sine vibration IEC68-2-6 Fc	5g/0,55mm, 500Hz, 10m, 4 worst freq		

Options

The ordering code of the products in this data sheet is "S1503/00".

ConfiLib, Saccess, and software development kits (SDK) are separately available.

TagMaster AB

Electrum 410 Tel +46 - (0)8 632 1950
S-164 40 KISTA Fax +46 - (0)8 750 5362
Sweden
Email: confident@tagmaster.se
Web: <http://www.tagmaster.com>

This document

Specifications are subject to change without prior notice.

Representative:

\dS1503af\9909

