

TagMaster AB

MarkTag™ S1255

Multiple access R/O Card

MarkTag S1255 is a 2.45 GHz identification tag that can be read at a distance, also if several tags occupy the reading zone.

Each tag has been permanently programmed with an 8 decimal number from the factory, and this "mark" is unique to all tags in the Confident family.

The programmed code comprises a 32 bit checksum for automatic verification of the "mark", thereby effectively eliminating substitution errors even if the tag is far away or when several tags are read in the same zone.

An environmentally harmless lithium cell gives long reading range and a high speed, and the cell life is independent from how often the tag is read.

The cell resists long term operation at elevated temperatures. When the capacity is about to run out, a status bit is set to give automatic warning to the user via the tag reader.

MarkTag S1255 can be fitted by a clip, a credit card holder and by magnetic or adhesive tape. It is also prepared with holes for mounting with M3 screws. To use clip and/or screw fastening, the holes are punched out with a separately available tool.

The design is vibration resistant, watertight, corrosion free, UV stable and withstands chemicals. The front panel is made from a polymer that can be printed according to user requirements. The back panel is printed with type code and serial number, and is permanently attached to the front panel.

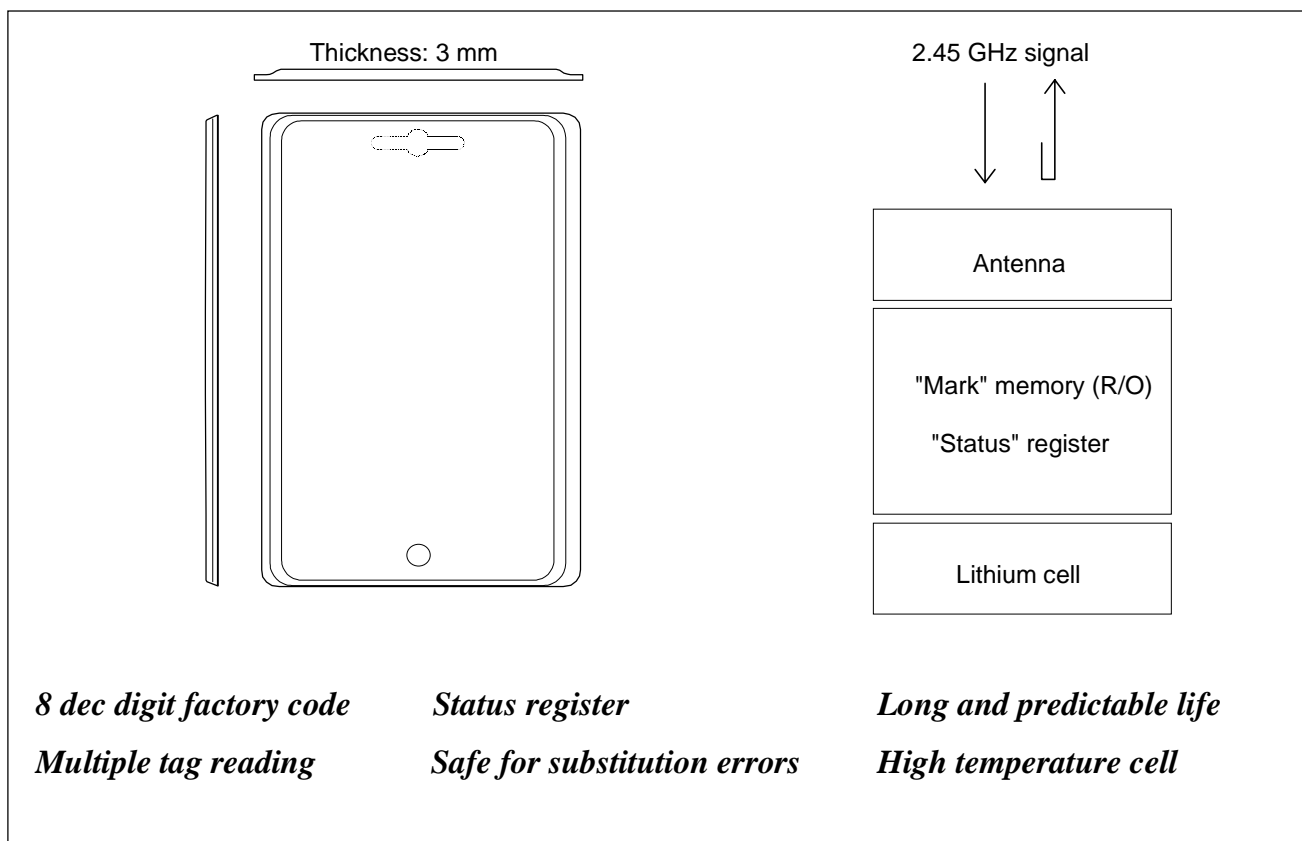

Reading range

MarkTag S1255 receives and reflects its signals through the front panel and rejects signals in the back direction. The maximum reading range is defined by a number of factors. All resulting in an R parameter for the Confident Tag and Confident Communicator combination in use. Multiply these factors and you get the resulting reading range in meters.

Example: The $R_{1255, \text{high speed}}$ for S1255 is 1.25 and the R_{1500} for the S1500 communicator is 2.7, resulting in a reading range of $1.25 * 2.7 = 3.4$ meters

The tag reads at all distances from the maximum reading distance down to zero. The maximum reading range can be reduced by power and sensitivity setting commands in the communicator.

The lobe is unaffected if the tag is mounted on a metal surface, and non metallic materials in front of the tag usually have little effect on the range.

If the communicator has circular polarisation, like WiseMan S1500 and WatchMan S1501 have, the reading range will be insensitive to rotation around the communicator's radiation axis.

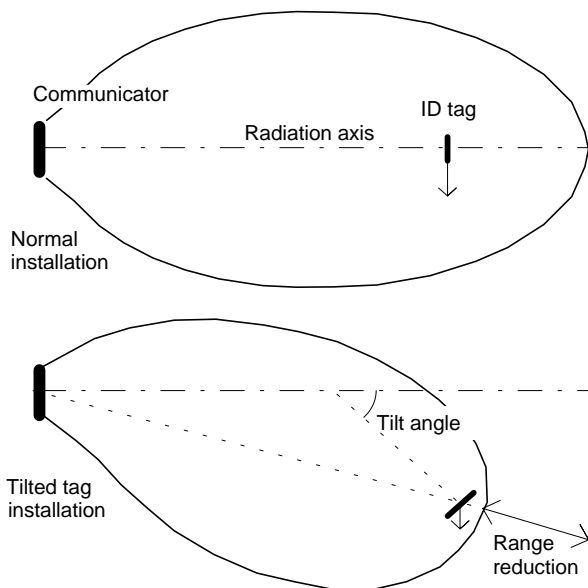

If the tag is very tilted in relation to the radiation axis, the shape of the communication zone will be modified. The range reduction is approximately 30 % if the tag is tilted by 45°.

The figure shows the situation with an ellipsoid lobe communicator, such as WiseMan S1500 or WatchMan S1501.

Communication

The ID tag repeatedly reflects information to any illuminating communicator. This reflection is wide band, i.e. reading works on all channels within the frequency band. If communicators at different channels simultaneously illuminate the tag, it will be safely read by all of these without interference.

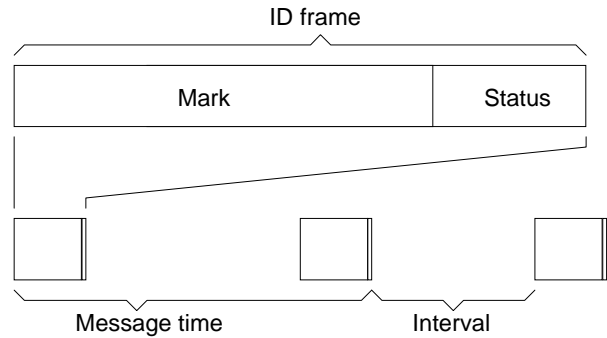

Reflections comprise the factory coded "mark" number from the R/O memory, including a 32 bit checksum, and the "status" field. A "mark" + "status" sequence is called an "ID frame".

The ID frame is reflected from the tag with random intervals. An interval plus leading and trailing ID frames is called a "message time".

The maximum message time (T_{mm}), that is the longest time that can ever occur to transfer two complete ID frames with an interval in between, is always less than 150 ms. The average time is however only 80 ms, which means that the tag reflects its ID frame about 12 times every second.

Tag life

The lithium cell life is typically 6 years. Since the ID tags are always "awake" and reflect their data, the cell life is independent of how often the tags are read. Electromagnetic interference cannot "wake up" the tag and cause unintended discharge.

The lithium cell is specially designed for long term, high temperature operation, such as when the tag is installed in a car window. The cell in itself has a capacity deterioration of about 0,5% per year and if stored at 80°C for 2.000 hours, the capacity loss is only about 10%.

The cell is from a manufacturer that has life recordings spanning up to 15 years (1995) for the category of lithium cells used in S1255. The lithium cell has been qualified against the UL safety standards and does not contain corrosive or toxic active materials.

Multiple tag operation

Since S1255 emits its ID frames at random intervals, it is possible to read several tags at the same time as is shown on the picture below:

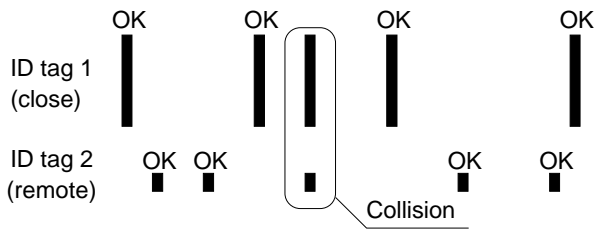

When collisions occur, a checksum algorithm in the communicator cancels these ID frames.

In a worst case situation, e.g. if the tags would all be remote and at the range limit, or subject to strong interference, the likelihood for a substitution error (wrong interpretation) is less than one in $5 \cdot 10^9$ read tags thanks to the 32 bit checksum.

This means that in all practical cases it can never happen that an ID tag is wrongly interpreted.

The time to read all tags in the zone is shown below.

<u>Tags in the zone</u>	Average (ms)	99% (ms)	99,9% (ms)
2 tags	150	350	500
3 tags	250	550	800
4 tags	300	750	1000
5 tags	400	900	1250
6 tags	500	1200	1600
7 tags	650	1500	2000
8 tags	800	1800	2700

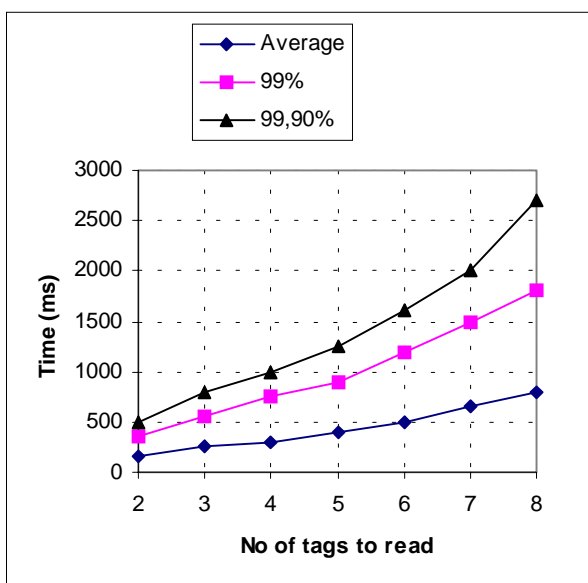

ID tag holders

Different ID tag holders are shown below. Please refer to the individual data sheet for more information.

Vertical badge

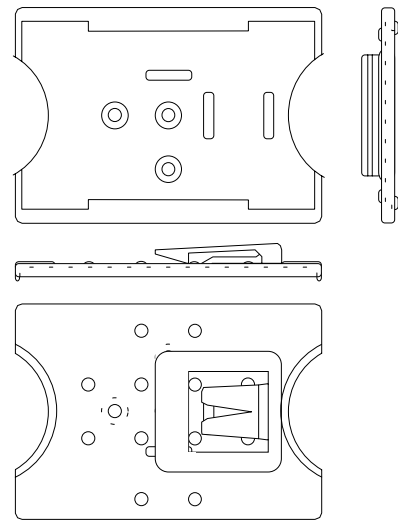

Horizontal badge

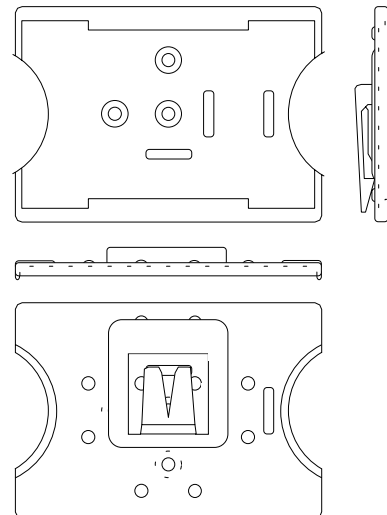

Car window

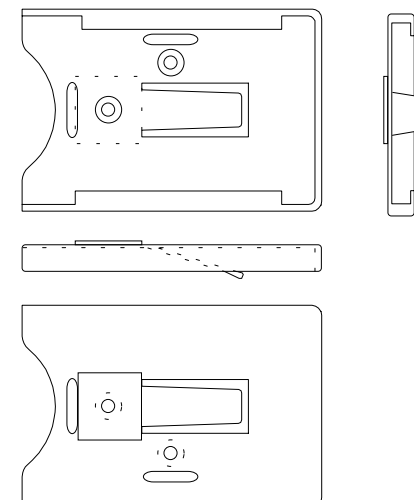

Mechanical data

Product information according to the figure below is printed on the MarkTag back panel.

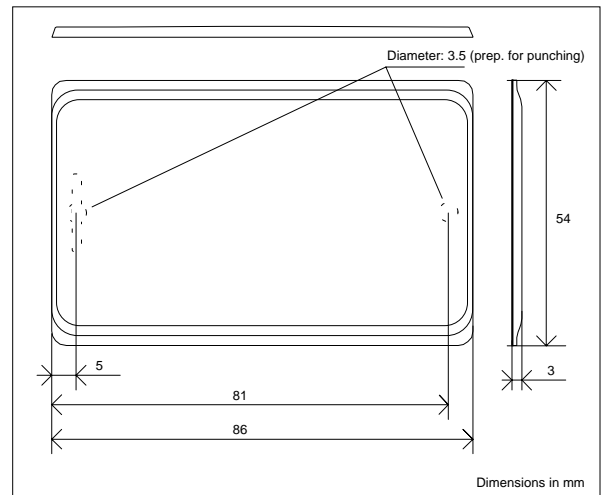
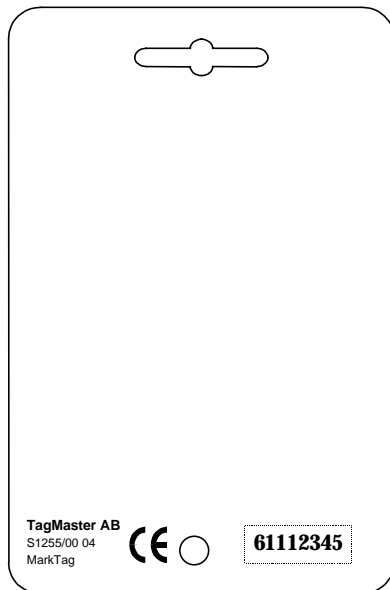

Weight	15 grams
Front colour	Light grey
Back colour	Light grey
Front material	Polymer
Back material	Polymer
Sealing method	Adhesive

The revision code is for internal use only.

For security reasons, there is no relation between the serial number and the 8 digit electronic “mark“. Both are running numbers that never are repeated.

Communication range data

Reading range parameter:	$R_{\text{low speed}}$	-	-
	$R_{\text{high speed}}$	1.25	(3.4m with S1500 and S1501, 5m with S1503)
Writing range parameter:	W	-	-

The interpretation of the R and W parameters are described in the Communicator data sheets S1500, S1501 and S1503.

Environmental data

Cold IEC68-2-1 Ad	- 20 °C	Shock IEC68-2-27 Ea	500 g 1 ms, 100x 3 dir	Immunity prETS 300 683	Acc. to CE leg.
Heat IEC68-2-2 Bd	+ 85 °C	Bump IEC68-2-29 Eb	40 g 6 ms, 1000x 3 dir	Emission I-ETS 300 440	Acc. to CE leg.
Sealing IEC 529	IP 67	Free fall IEC68-2-32 Ed	1,0 m, 100x	Solar radiation IEC68-2-5 Sa C	1120 W/sqm 56 days

Options

The ordering code of the product in this data sheet is “MarkTag S1255/00”.

TagMaster AB
Electrum 410 Tel +46 - (0)8 632 1950
S-164 40 KISTA Fax +46 - (0)8 750 5362
Sweden
email: confident@tagmaster.se
<http://www.tagmaster.com>

This document

Specifications are subject to change without prior notice.

Representative:

ds1255de\ 9909

