



- 22k Bytes user RAM**
- High Speed Inputs**
- 16 Digital Inputs**
- 8 Relay Outputs**
- RS232 communication port**
- LED Indicators**
- Real Time Clock**
- CE Compliant**

Introduction

The FMT-100A provides 16 digital inputs and 8 relay outputs and a RS232 communication port. It is part of the FMT range and is programmed using the FLEX PC programming software. All the FMT range can be programmed using a high level text based language as well as ladder programming and benefit from advanced programming features such as 32 bit mathematics, far more advanced features than a standard PLC. The typical connections along with the ratings and descriptions are shown in the following tables. For information relating to programming or the internal facilities available see your FLEX32 on-line help.

General Ratings

Storage temperature	-20 to +70 °C
Operating temperature	0 to 50 °C
Humidity	0-90%
Battery life	Typically 5 years un-powered 10 years powered
Weight	Typically 300g
Dimensions	75 mm wide 125 mm long 52.5 mm high
Screw terminal wire gauge	Up to 4 mm csa (14 AWG)
Supply currents	Typically 52 mA @ 12VDC Supply
Output type	8 relay outputs, normally open contacts
Output rating	1A at maximum contact voltage of 48V
Input type	16 opto-isolated digital inputs
Input rating	Approx. 5 mA @ 12VDC
High-Speed Inputs	Inputs 0 - 1 are High-Speed Inputs, upto 10KHz



Connection Details

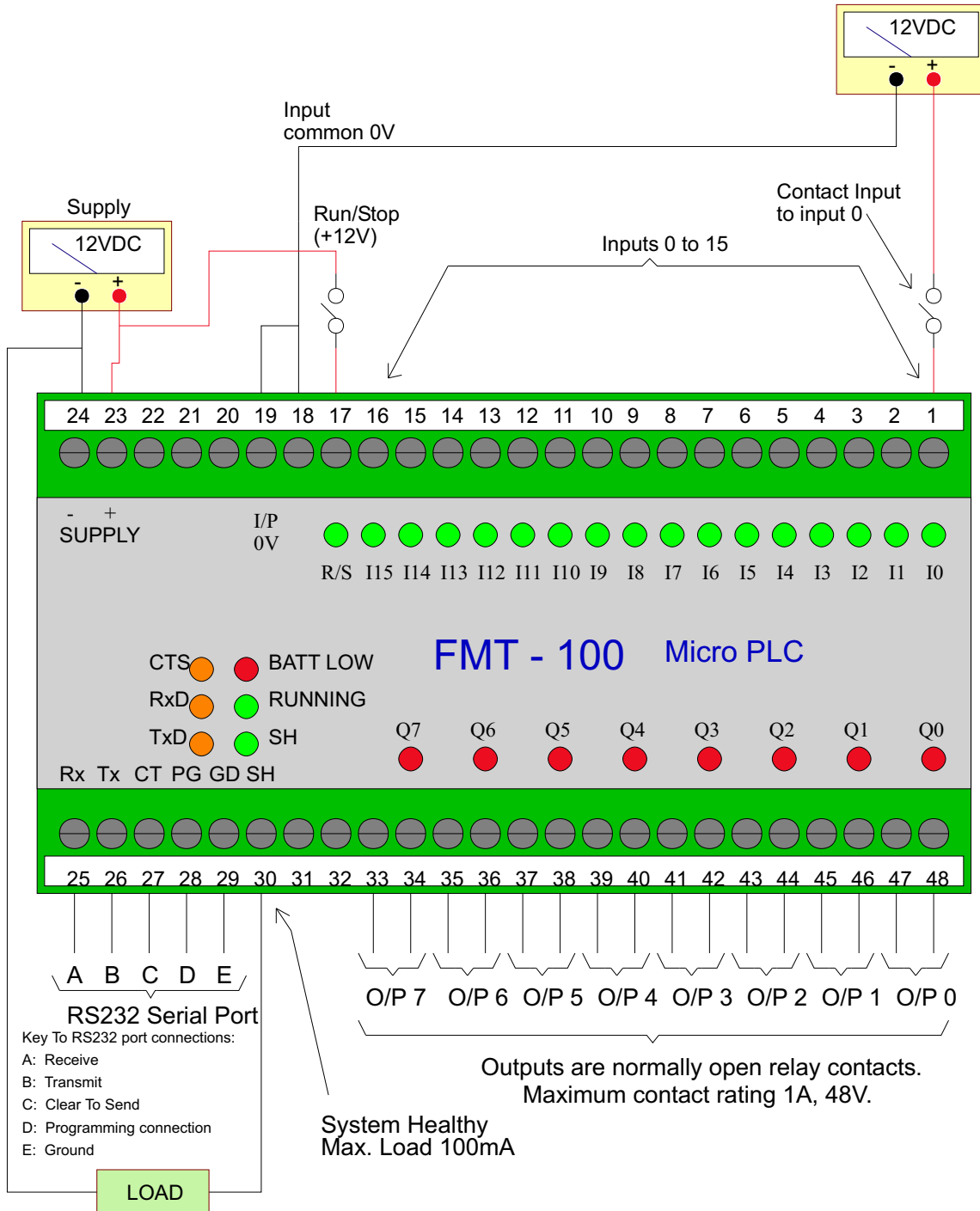



LED Descriptions

Label	Colour	Description
I0 - I15 & Run/Stop	Green	Indicates status of the digital input. When illuminated the external input is energised.
Q0-Q7	Red	Indicates status of the digital output. When illuminated the relay output is turned on.
CTS	Yellow	Indicates status of the external Clear To Send input. When illuminated the CTS line is high and the FMT will send data out of the RS232 port.
RxD	Yellow	Indicates status of the RS232 receive data line input. When flashing, data is being received by the FMT.
TxD	Yellow	Indicates status of the RS232 transmit data output line. When flashing, data is being sent out from the FMT.
Batt Low	Red	When illuminated the battery requires replacement. Note IF7 also reflects this state.
Running	Green	When illuminated the FMT is running the user program stored inside. Flashes quickly after power-up whilst the FMT is testing the integrity of the program.
SH (system healthy)	Green	This is normally on but will go out in the event of an internal failure of the microprocessor.

Terminal Descriptions

Screw Terminal No.	Description	Nominal Rating	Maximum Rating (not continuous)	Notes
1 - 2	Inputs I0 to I1	12V (+/-20%) where: <3V = OFF >9V = ON	24V < 1 Second	The input current at 12V is typically 5mA. These inputs can be used for high speed options.
3 - 16	Inputs I2 to I15	12V (+/-20%) where: <3V = OFF >9V = ON	24V < 1 Second	The input current at 12V is typically 5mA
17	Run/Stop	12V (+/-20%) where: <3V = RUN >9V = STOP	24V < 1 Second	The input current at 12V is typically 5mA. If no connection then FMT will RUN.
18 - 19	0V return for Inputs on terminals 1 to 9	N/A	N/A	The above 17 inputs return to this terminal but are otherwise fully isolated from all other connections to the FMT.
20 - 22	No connection	N/A	N/A	N/A.
23	FMT +VE supply connection	7 - 60V	7 - 60V	This supplies all the internal needs of the FMT.
24	FMT 0V supply connection			
25	Receive RS232 data (input)			
26	Transmit RS232 data (output)			
27	Clear to send (input)			Used to interface FMT to slow external devices such as panel printers. Leave disconnected if not required.
28	Program			Connect to terminal 29 when using the FLEX programming package. Leave disconnected for all other operations.
29	Ground			Used as the common for the RS232 connections on terminals 25, 26 & 27.
30	System Healthy	Sourcing 100mA form supply on pin 23.	Max. 250mA < 1 second	
31 + 32	No connection	N/A	N/A	N/A.
33 + 34	Output Q7 relay contacts	1 Amp @ 48V	1 Amp @ 48V	Normally open relay contact.
35 + 36	Output Q6 relay contacts	1 Amp @ 48V	1 Amp @ 48V	Normally open relay contact.
37 + 38	Output Q5 relay contacts	1 Amp @ 48V	1 Amp @ 48V	Normally open relay contact.
39 + 40	Output Q4 relay contacts	1 Amp @ 48V	1 Amp @ 48V	Normally open relay contact.
41 + 42	Output Q3 relay contacts	1 Amp @ 48V	1 Amp @ 48V	Normally open relay contact.



Terminal Descriptions (continued)

Screw Terminal No.	Description	Nominal Rating	Maximum Rating (not continuous)	Notes
43 + 44	Output Q2 relay contacts	1 Amp @ 48V	1 Amp @ 48V	Normally open relay contact.
45 + 46	Output Q1 relay contacts	1 Amp @ 48V	1 Amp @ 48V	Normally open relay contact.
47 + 48	Output Q0 relay contacts	1 Amp @ 48V	1 Amp @ 48V	Normally open relay contact.

RS232 Communications Port

The FMT-100 has one communication port. The connections to terminals 25 to 29 are the RS232 connections for RS232 devices. If a 9 pin D-type connector is required then a FMT-374 adapter board (see separate data sheet) can be screwed into the terminals. The maximum baud rate of the RS232 port is 19200 bps

Screw Terminal No.	Designator	Input or Output	D-type pin number (if using FMT - 374)	Notes
25	Rx (receive data)	Input	2	
26	Tx (Transmit data)	Output	3	
27	CT (clear to send)	Input	5	Leave disconnected if not required.
28	PG (programming)	Input	6	Connect to GD when programming. Leave disconnected otherwise.
29	GD (Ground)	COMMON	7 & 8	

Changing the Battery

The internal battery can be replaced as follows.

- * Disconnect the FMT from all external connections and remove from DIN rail.
- * Slide a small screwdriver into the gap that is seen along the long edge between the base and side of the case.
- * By gentle prising the bottom of the case can be removed. The battery can now be seen and can be replaced with one of the same type.
- * If in doubt new batteries are available from your supplier.
- * It will normally be necessary to re-program the FMT after the battery has been replaced.
- * If the program is stored in the PROM then the program is preserved but if the battery becomes flat then any variables that are preserved in start-up mode (IR2) will be lost.
- * Note that the orange DIN rail lever on the base fits into the slot on the side of the main case when refitting the base.

NOTE: Depending on the state of charge of the old battery you have up to one minute after the old battery is removed to swap the batteries before volatile information (such as date/time and preserved facilities) is lost.



Fitting a PROM

If it is required that the program is to be stored within the internal PROM fitted in the FMT-100, or if a new system PROM that has been supplied needs to be fitted then the following procedure should be followed: (Note: It is somewhat complex to change the internal PROM, so if you are in any doubt as to your ability to do so then it may be advisable to contact your supplier who will be able to carry out the procedure for you).

- * Disconnect the FMT from all external connections and remove from DIN rail.
- * Slide a small screwdriver into the gap that is seen along the long edge between the base and side of the case.
- * By gentle prising the bottom of the case can be removed.
- * When the bottom has been removed gently tap the FMT bottom side down onto a non conductive surface. The complete PCB assembly will then come out. (It is advisable to ensure that the top with the label is still fitted to the case as this will assist to orientate the board when refitting).
- * Having now removed the PCB assembly it can be seen that it comprises of two boards. The larger board with the screw terminals is the processor board and the smaller board plugged on to the top of it is the I/O board.
- * The I/O board should now be unplugged from the processor board using finger pressure only, anything else is likely to result in damage to the FMT. The I/O board will be a very tight fit and will need to be eased up a small amount alternately at each end until it becomes free.
- * By looking at the processor board it can be seen that at one end (marked on the board as END A) the PROM is plugged into a socket. The PROM is awkward to remove and is best done with a double hooked PROM extractor that will allow the PROM to be removed and a new one fitted. Make sure that the replacement PROM is fitted the correct way around.
- * The I/O board can now be re-fitted on to the processor board in a reverse manner to the removal process. Make sure that the I/O board is fitted the correct way around. To check for correct orientation there should be marked END A and END B on both the I/O and the processor board (the writing may be very small on the I/O board) the ends must coincide, i.e. END A on the processor must be below END A on the I/O board. (Another check is that the small black rectangular cased component should be above the PROM that has just been fitted).
- * The rest of re-assembly is the reversal of the dismantling process. Use the LED's on the I/O board to ensure that you refit the assembly correctly back into the case. Note that the orange DIN rail lever on the base fits into the slot on the side of the main case.

NOTE: USE CORRECT ANTI-STATIC ELECTRICITY PRECAUTIONS WHEN CHANGING PROMS.



Critical Applications

The FMT (or indeed any microprocessor based control system) must never be used in an application where failure of the device will endanger human life. When controlling machines such as presses, guillotines, etc. any critical functions must firstly fail safe and secondly be electrically or mechanically devised so that any failure cannot endanger personnel. When an application will not harm personnel but PLC malfunction will damage machinery or product we recommend utilising the System Healthy output. A typical circuit could be as follows:

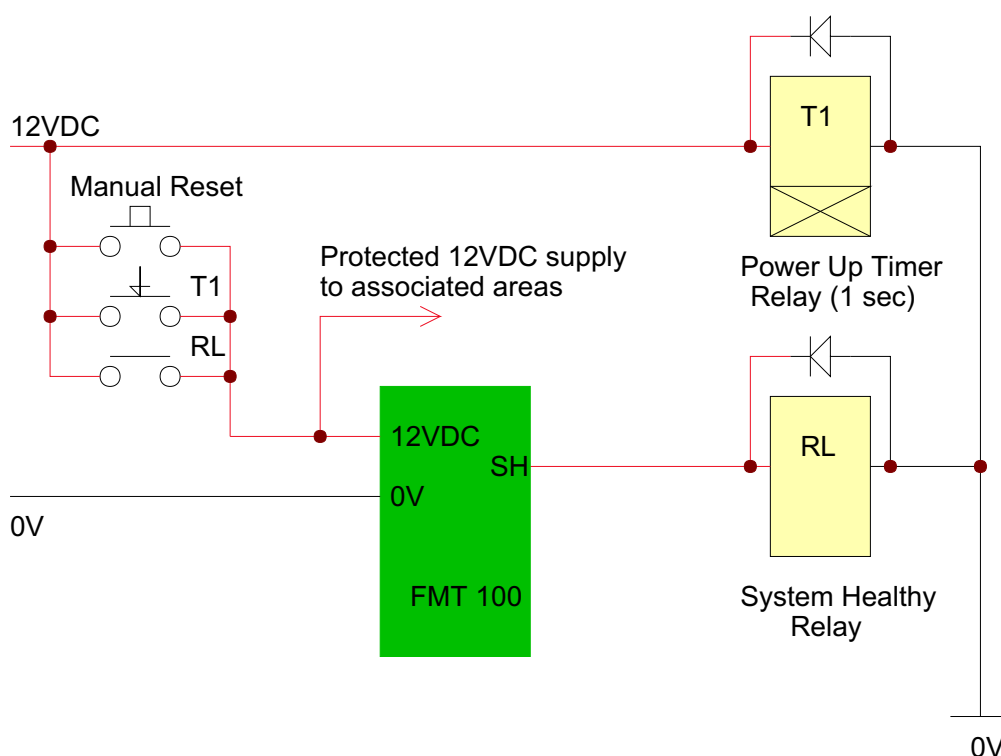

Installation

The FMT-100 can be mounted in any plane onto DIN rail that meets EN 50022. It is recommended that a minimum gap of 60mm be provided from the outside of the FMT-100 case to any wire trunking around it. It is recommended that any high voltage or high current cables be routed elsewhere in the panel to avoid running next to the FMT.

Note: Ensure screw terminals are fully un-screwed before inserting wire and tightening the screw. The reason for this is if the screw is screwed up and then the wire is inserted then the wire will go underneath the saddle clamp of the terminal which may not be initially obvious but will be an unreliable connection. To test for a secure connection, tug the wire and check that it can not be removed after tightening up the terminal screw.

High Speed Features

The FMT-100 hardware includes circuitry to process high speed events on inputs 0 and 1. These inputs can be configured to implement one of the following high speed facilities.

- * Incremental Pulse Encoder.
- * High Speed Counter.
- * Fast Edge Catching
- * Interrupt Driven Instruction Language Modules (see note)

The FMT-100 supports two inputs (I0 - I1) using W0 as the counter. The operation of the high speed features is set-up in one of the Internal Registers - IR74 to IR77 (in FLEX2) or by using the 'high speed' page in the project configuration window of FLEX32. For more information see our additional datasheet titled "High Speed Features".

Note: The FMT range has the ability to benefit from interrupt driven instruction language modules. This will enable a module to execute if an external interrupt is detected i.e when an input is switched on by some external signal.

The entire module will be executed when the input that is specified comes on. To make a module interrupt controlled you should either select 'Control' in the Instruction Module Editor (FLEX32) or in the project configuration screen (FLEX 2).

The maximum number of steps of code that can be executed in one interrupt is twenty, more than this and the firmware will raise an 'Input Interrupt overrun' error.

EMC Compliance

The FMT 100 range has been tested and fully complies with EN 50081-1 and EN50082-2 and are therefore CE marked but it is necessary to ensure that external equipment is connected correctly.

The standards are as follows:

- * EN50081-1 Generic emissions standard for light industrial applications.
- * EN50082-2 Generic immunity standard for industrial applications.

Following the provisions of EU EMC Directive(s) 89/336/EEC and 92/31/EEC.

Important Note: It is important for the reliability of the FMT-100 and to reduce electrically emitted noise that all D.C. inductive loads are suitably suppressed at source with a diode. This may also be necessary to comply with current EMC regulations. Any A.C. inductive loads can be suppressed with a suitable capacitor and/or resistor arrangement.



Data Sheet Issue: 1.31
Date: 10 May 2005

Order Codes

Part Number
FMT-100A

COLTER GROUP
COLTER PRODUCTS LIMITED

UNIT 7, ZONE C
CHELMSFORD ROAD INDUSTRIAL ESTATE
DUNMOW
ESSEX
CM6 1HD

Telephone: + 44 (0) 1371 876887
Fax: + 44 (0) 1371 875638

E-Mail: sales@coltergroup.co.uk
Web Site: www.coltergroup.co.uk

© Copyright 1999

The unit described on this datasheet is designed and manufactured in Great Britain by Colter Products Ltd.
Colter Products reserve the right to amend these specifications and the user is asked to check the validity of the data sheet prior to use